

ITEM NO.	DESCRIPTION
1	RAPID RAIL
2	SELF TAPPING SCREW
3	WASHER, EPDM BACKED
4	FLASHING
5	ASSY, BOLT
6	BASE, EPDM ATTACHED

1) Rapid rail

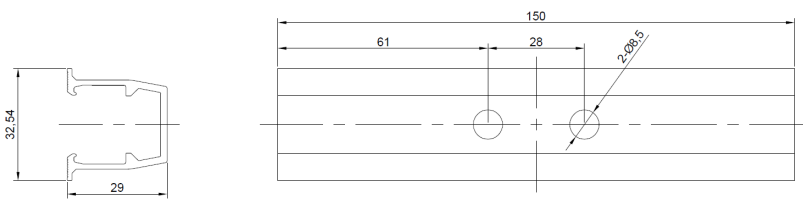

Property	Value
Material	Aluminum
Finish	Anodization, AA10

2) Self tapping screw

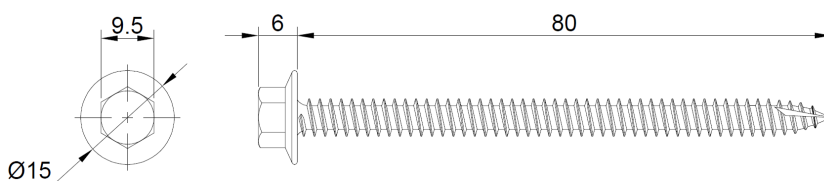

Property	Value
Material	Steel
Finish	Darcomet

3) Washer, EPDM backed

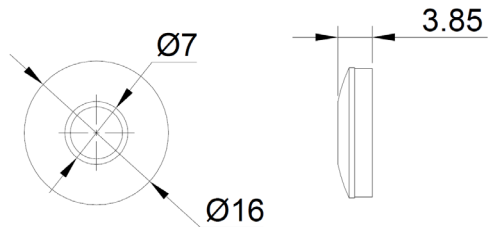

Property	Value
Material	Stainless steel
Finish	Clear

5) Assy. bolt

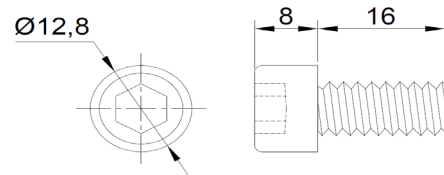

Property	Value
Material	SUS304
Finish	Mill

4) Flashing

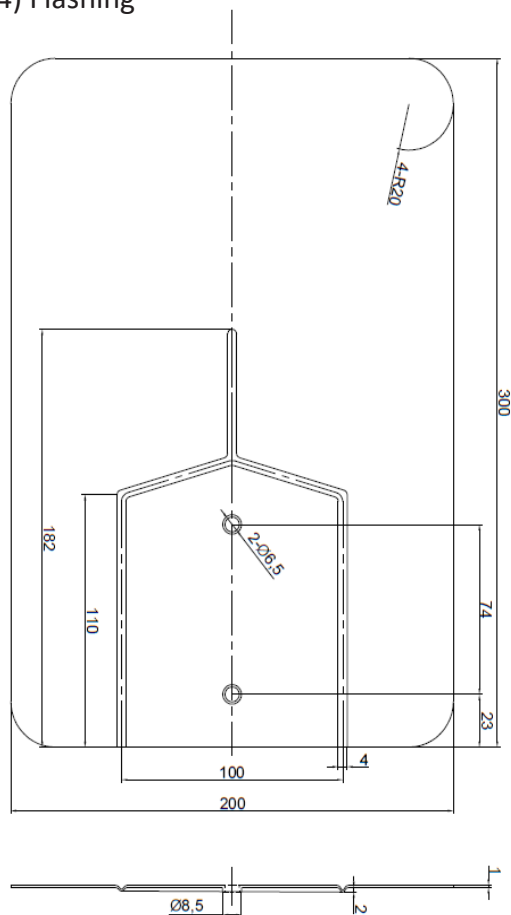

Property	Value
Material	Aluminum
Finish	Mill

6) Base

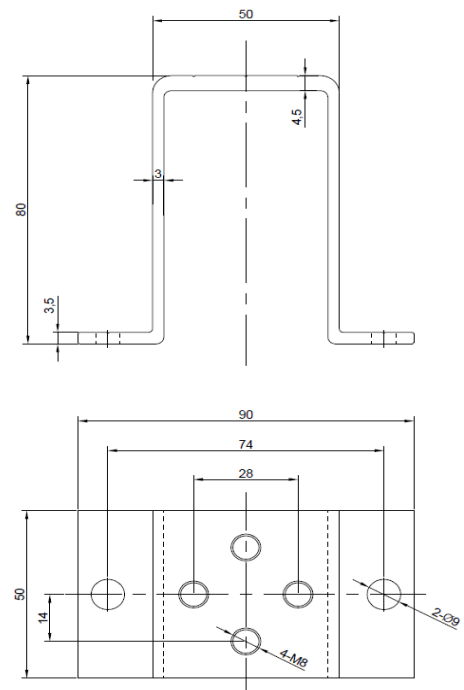

Property	Value
Material	Aluminum
Finish	Anodization, AA10