

Seat Arrangement Manual

Lufthansa

A320

**180 CC/MC
 MAX Cabin**

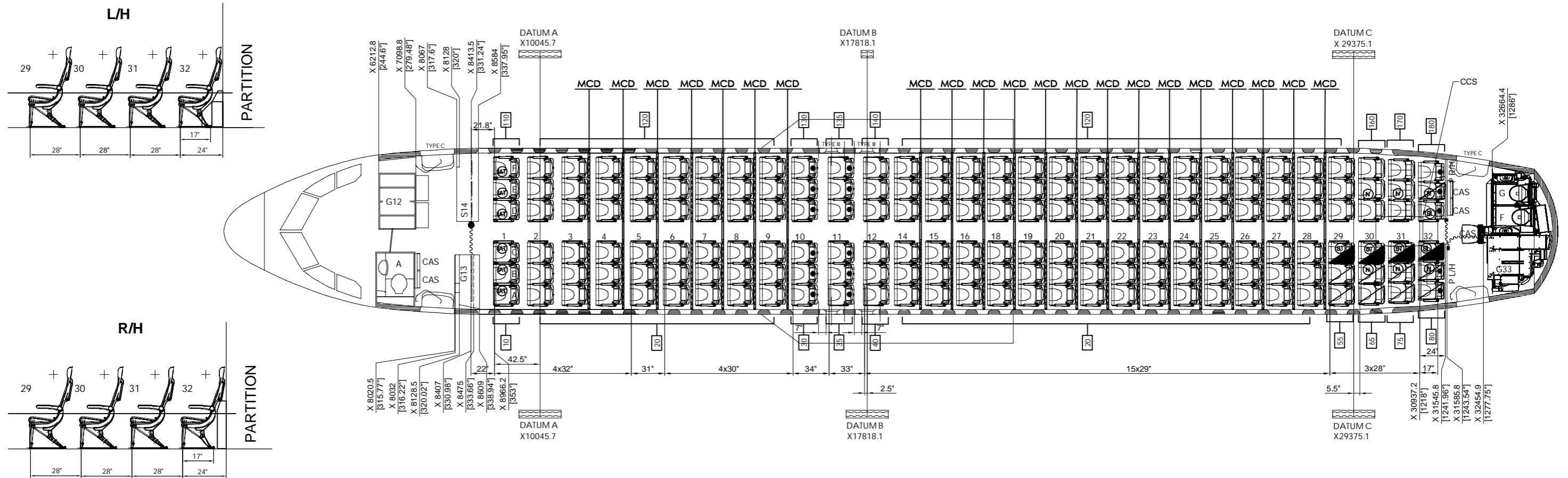

SYMBOLS

- G GALLEY
- S STOWAGE
- CAS CABIN ATTENDANT SEAT
- [20] SEAT POSITION NO.
- [MCD] MCD POSITION
- (IAT) IN ARM TABLE
- NO RECLINE
- (N) NARROW SEAT
- (SL) SPECIAL LEG 17"
- (ST) STRETCHER POSITION
- ~ CURTAIN STOW POSITION

NOTES

- SEAT PLACE NUMBERING SEE ROW 1
- SEAT LOCATION MEASURED FROM CENTER OF FWD SEAT STUD ON INBD. SEATTRACK
- FOR PART NUMBER INFORMATION SEE PAGE 1013-1014

STRETCHER INSTALLATION ON DEMAND

- [Symbol] STRETCHER ATTENDANT
- [Symbol] STRETCHER POSITION

STANDARD SEAT

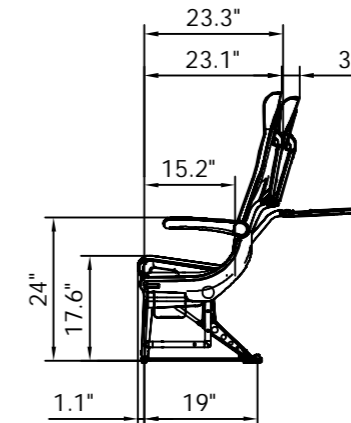

Drawn: 16.12.2015, Olga Mohrland
 Checked: 16.12.2015, Sebastian Bloch
 Released: 16.12.2015, Sebastian Bloch
 Revised:
 SAM-File: A320 MAX_Page 012_Rev 29.dwg