

PLASMA AIR - MODEL AFS-MF IONIZATION PRODUCT SUBMITTAL

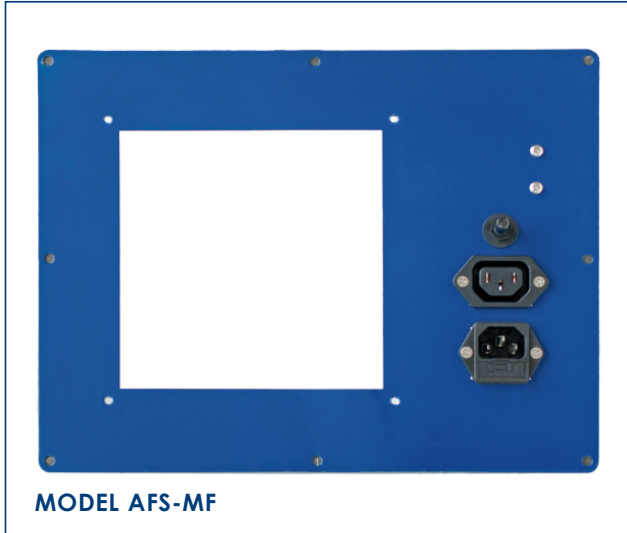

Ionization units should be powered when there is air flow in the system. The Plasma Air Model AFS-MF provides a convenient method for powering Series 100 and 200 Ionization Units. The AFS-MF is equipped with a pressure switch which closes at 0.05 inch WG. The unit can be used on either positive or negative pressure ducts. The AFS-MF can be installed in metal duct utilizing the factory supplied gaskets and pre-drilled flange. The unit is shipped complete with an electrical "jumper cord" and (4) 4 mm mounting screws to mount the ionization unit to the AFS-MF frame. The frame is mounted to the duct with sheet metal screws.

SPECIFICATIONS

Material:	16 gauge steel
Finish:	Heat cured powder coat
Gasket:	Neoprene EPDM
Weight:	2 pounds
Maximum Operating Temperature:	140° F (60° C)
Electrical:	
Voltage:	115V/230V
Power Consumption:	20 watts max
Current Draw:	0.2 amp max
Frequency:	50/60 hertz
Internal Fuse:	5 amp
Field Electrical Connection:	Nema 5 receptacle



DIMENSIONS: See Figure 1

